



Richard Petty

1980 Chevrolet® Monte Carlo

1/25th scale

18 years and older

made in the U.S.A.

salvinosjrmodels.com



Robert Glenn Johnson Jr. (June 28, 1931 – December 20, 2019), better known as **Junior Johnson**, was a stock car driver of the 1950s and 1960s. He won 50 races in his career before retiring in 1966. In the 1970s and 1980s, he became a racing team owner; winning championships with Cale Yarborough and Darrell Waltrip. Johnson was a master of dirt track racing. "The two best drivers I've ever competed against on dirt are Junior Johnson and Dick Hutcherson," said Ned Jarrett.

[Information courtesy of Wikipedia.org/wiki/Junior_Johnson]



OFFICIAL
LICENSED PRODUCT

General Motors Trademark Used Under License to Salvinos JR Models, Inc.

© 2021 All Petty Marks Used Under License from Petty IP, LLC

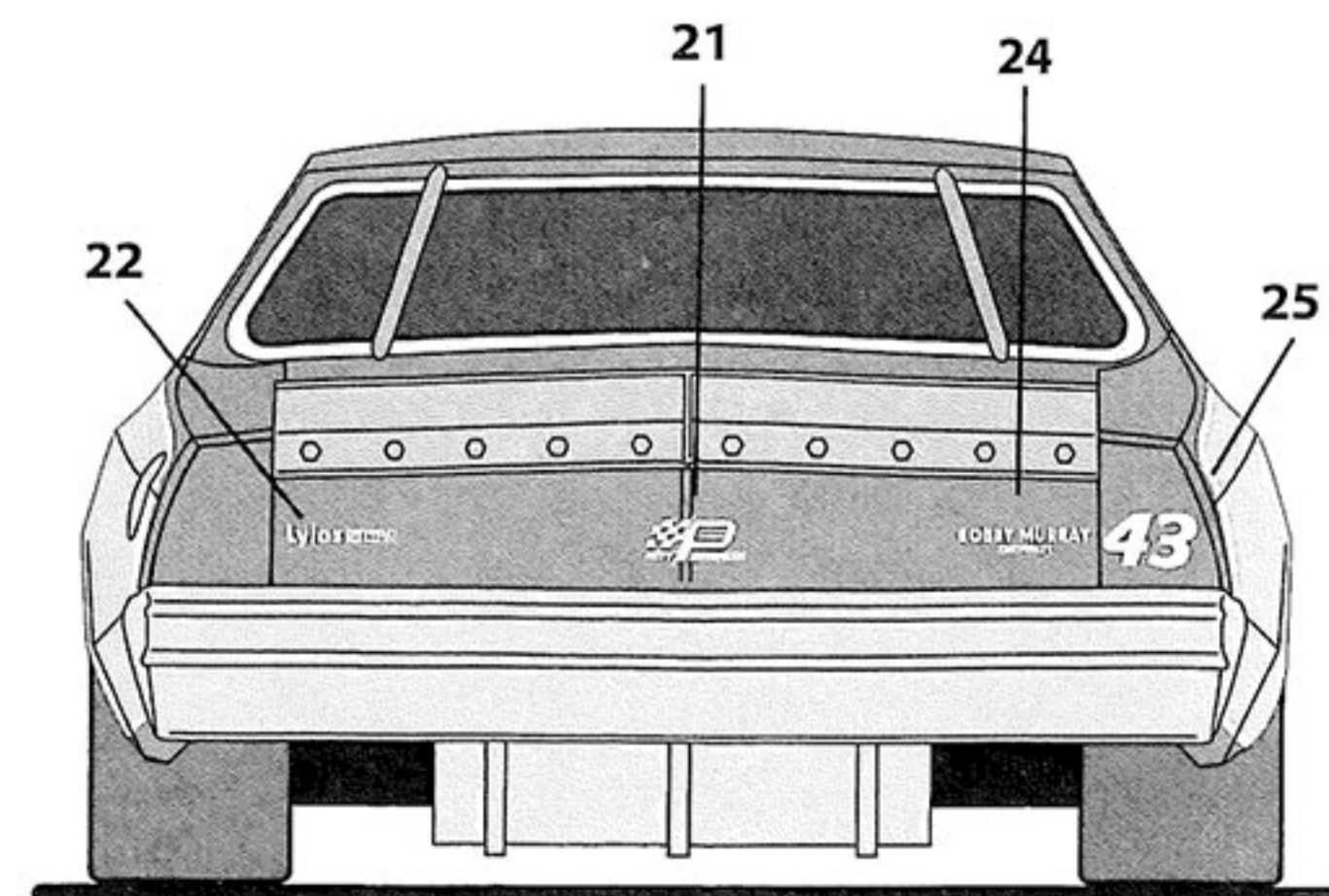
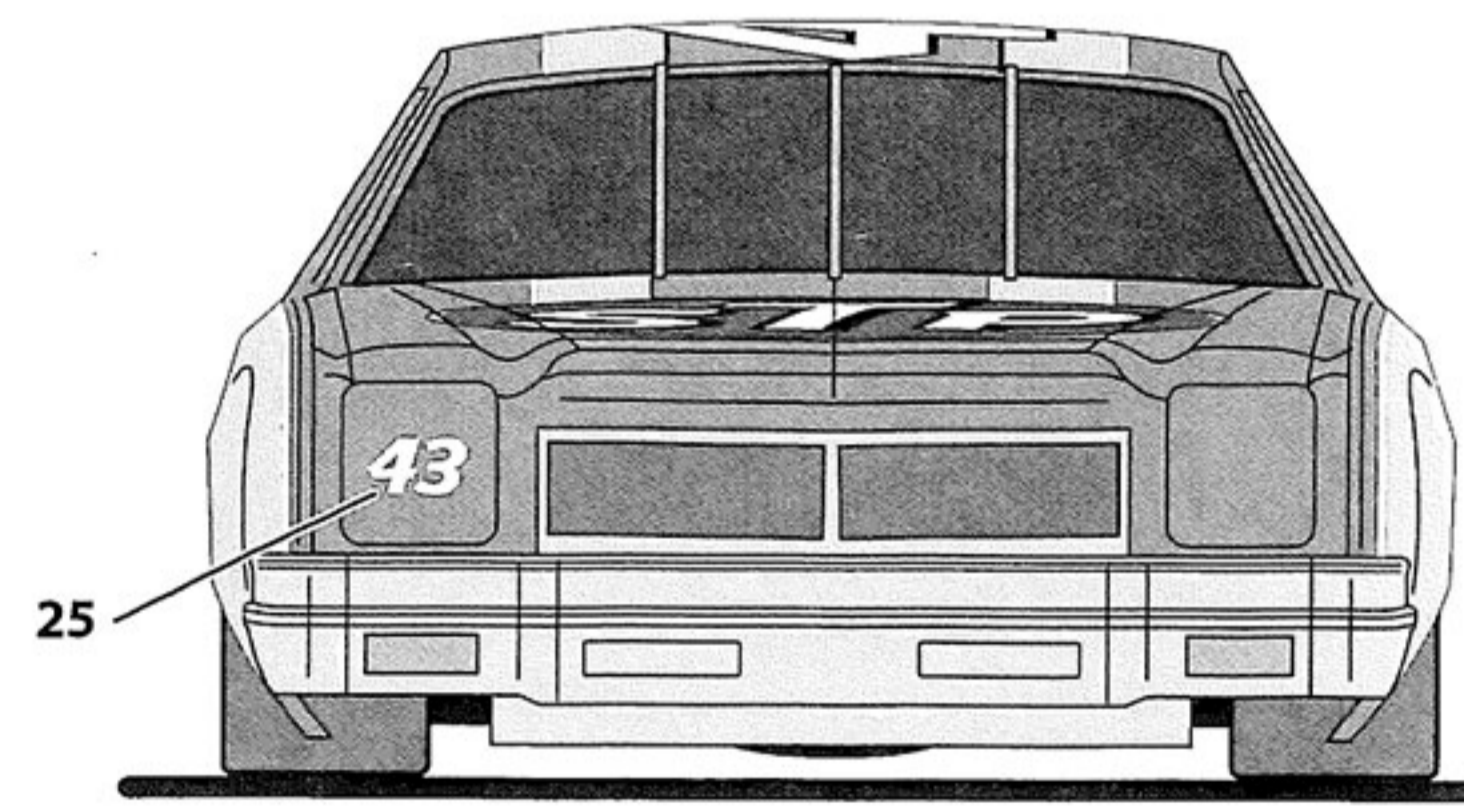
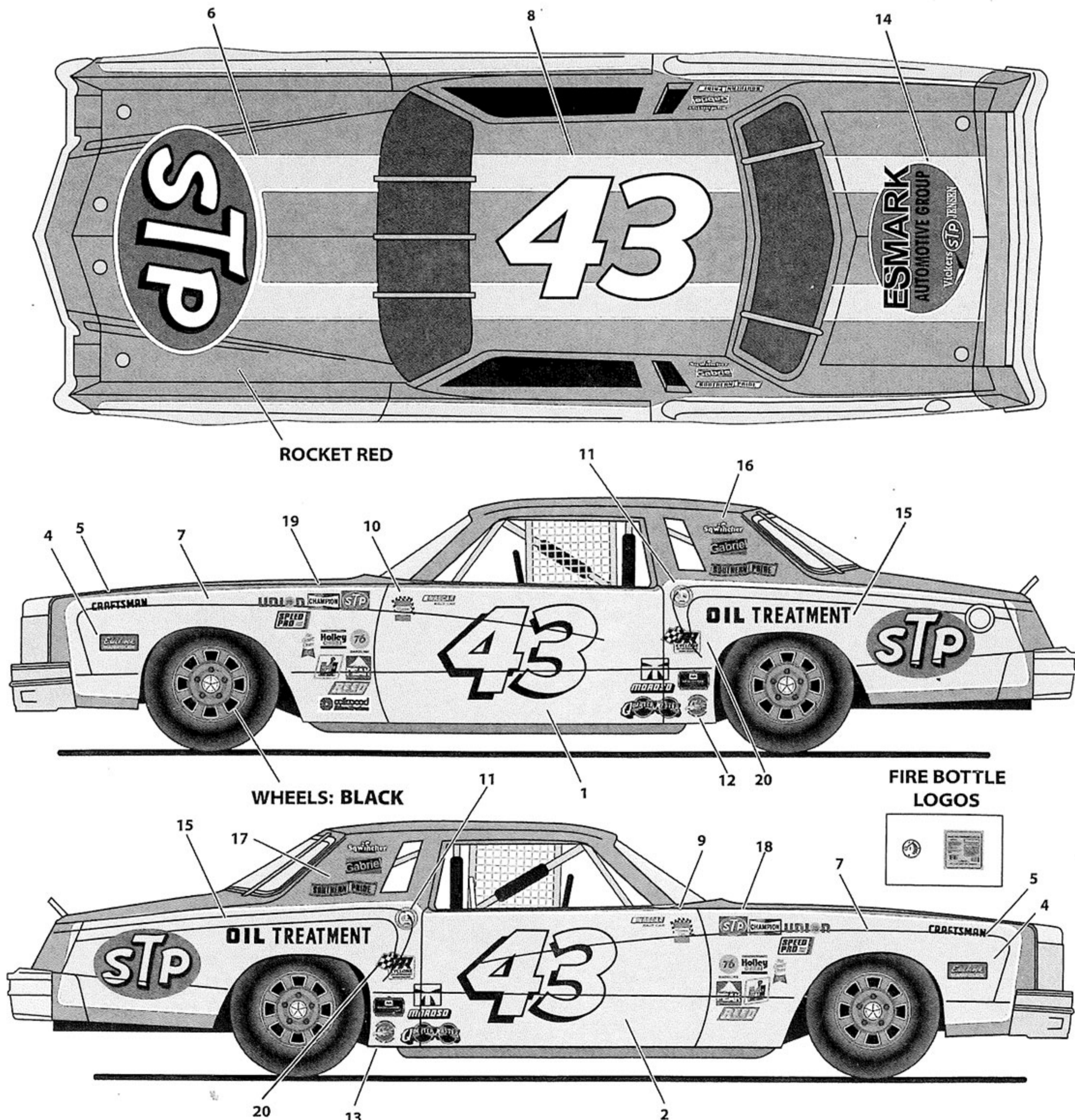

1

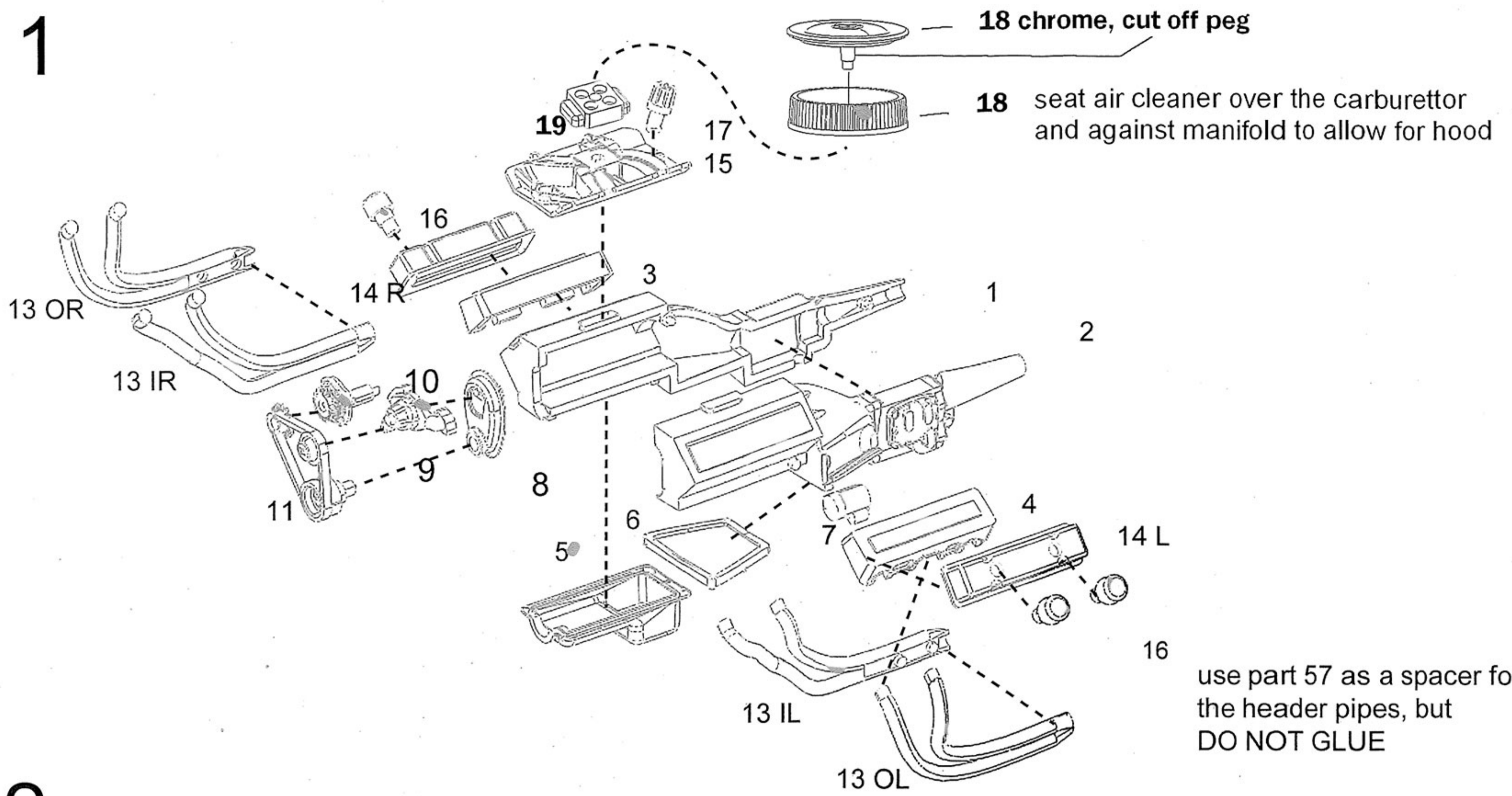

2

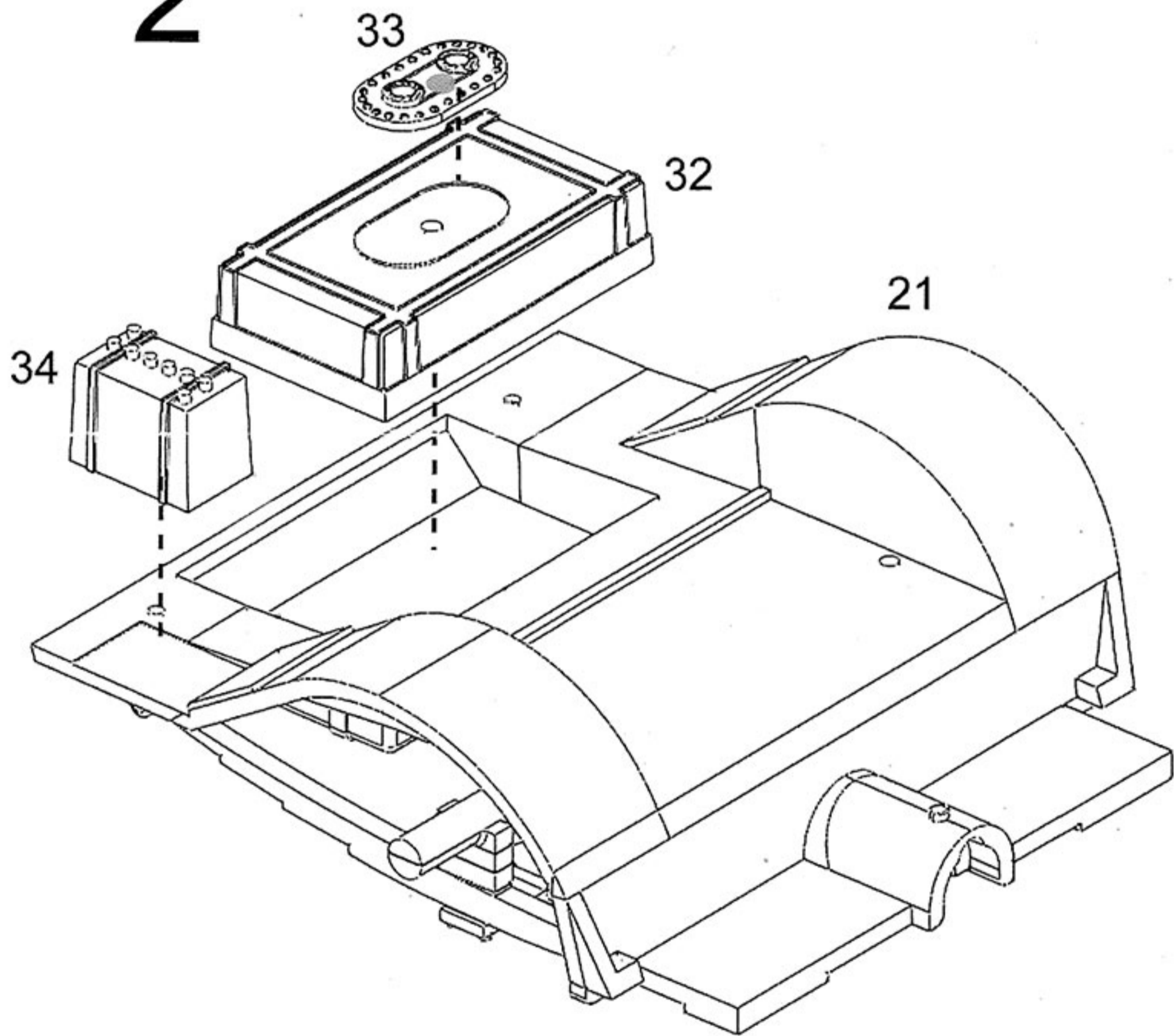

3

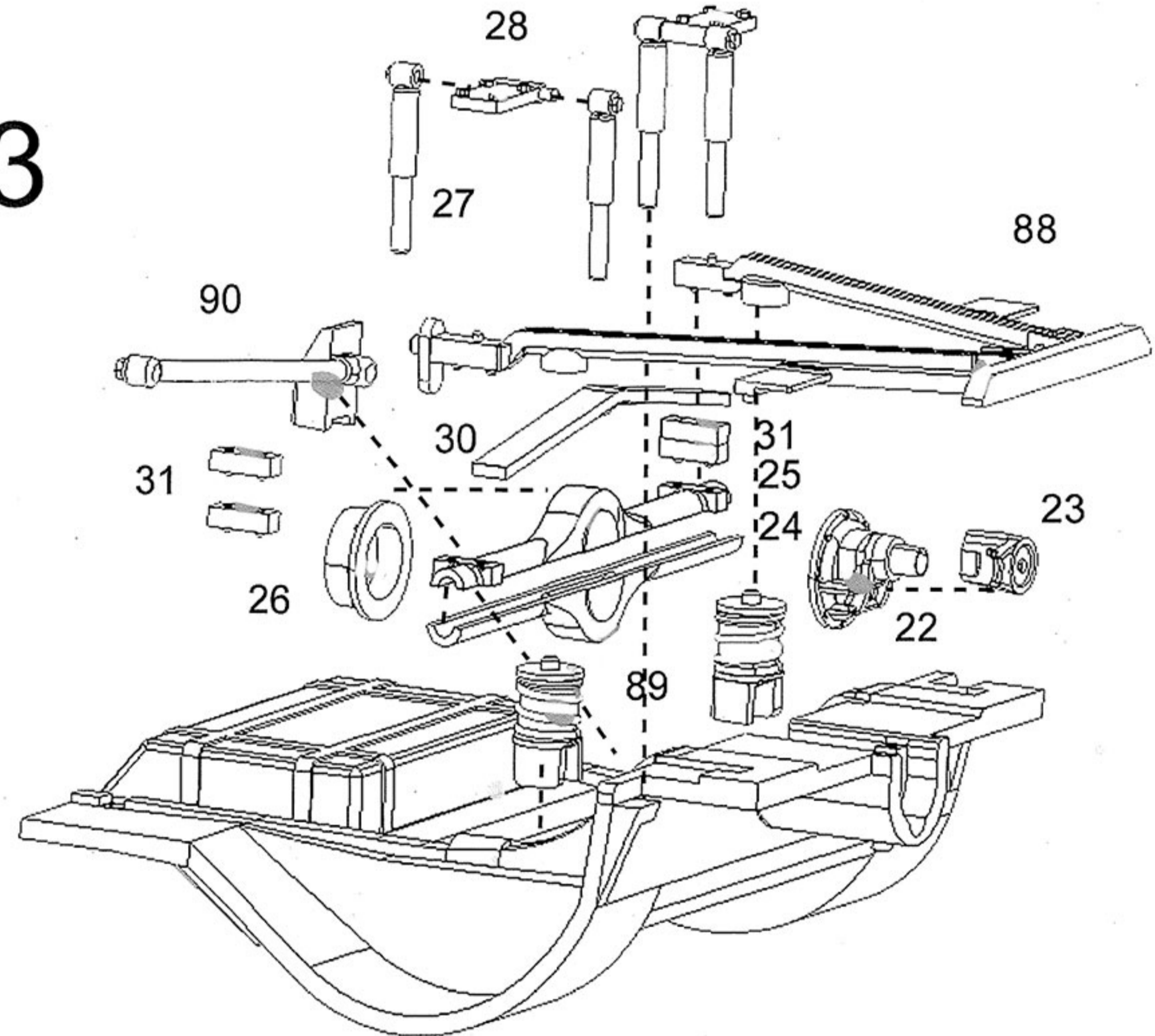

4

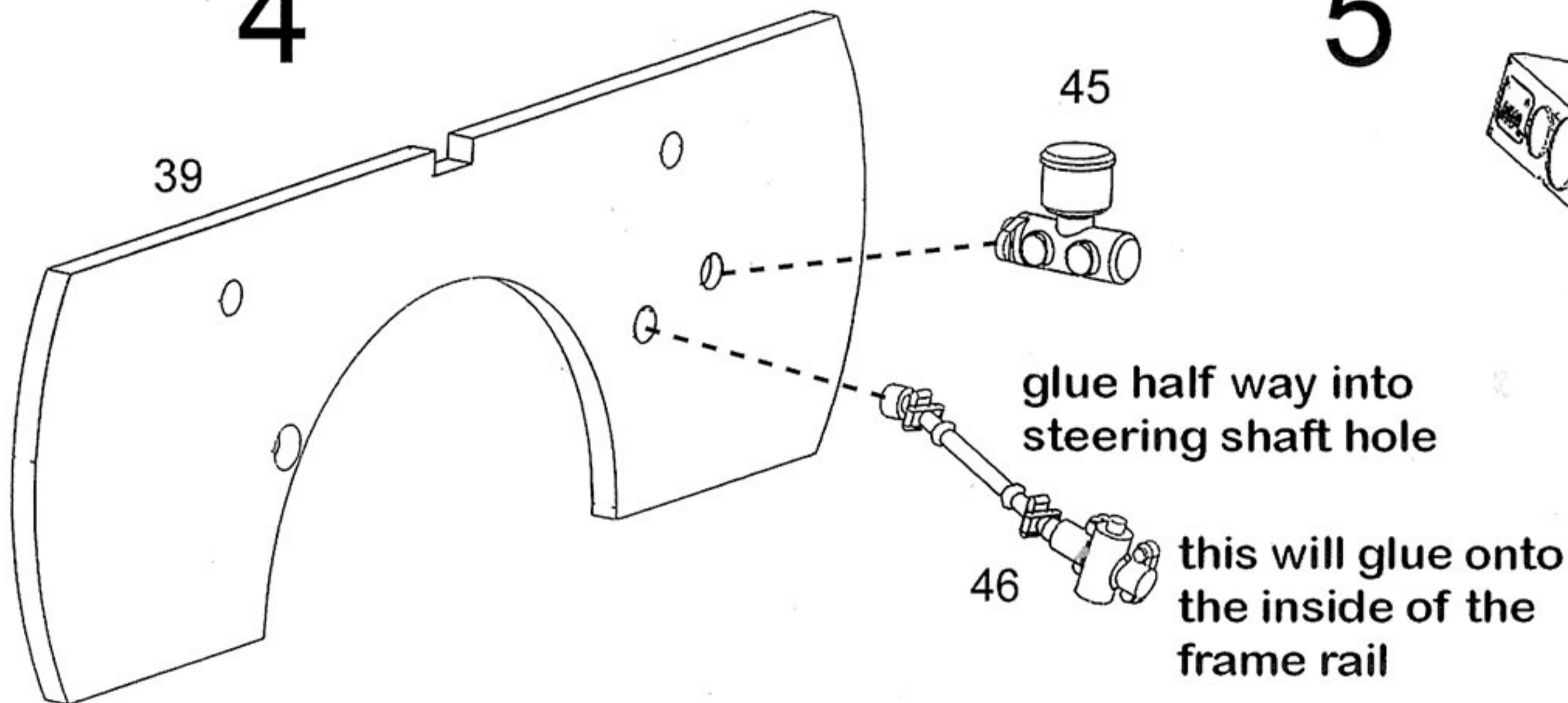

5

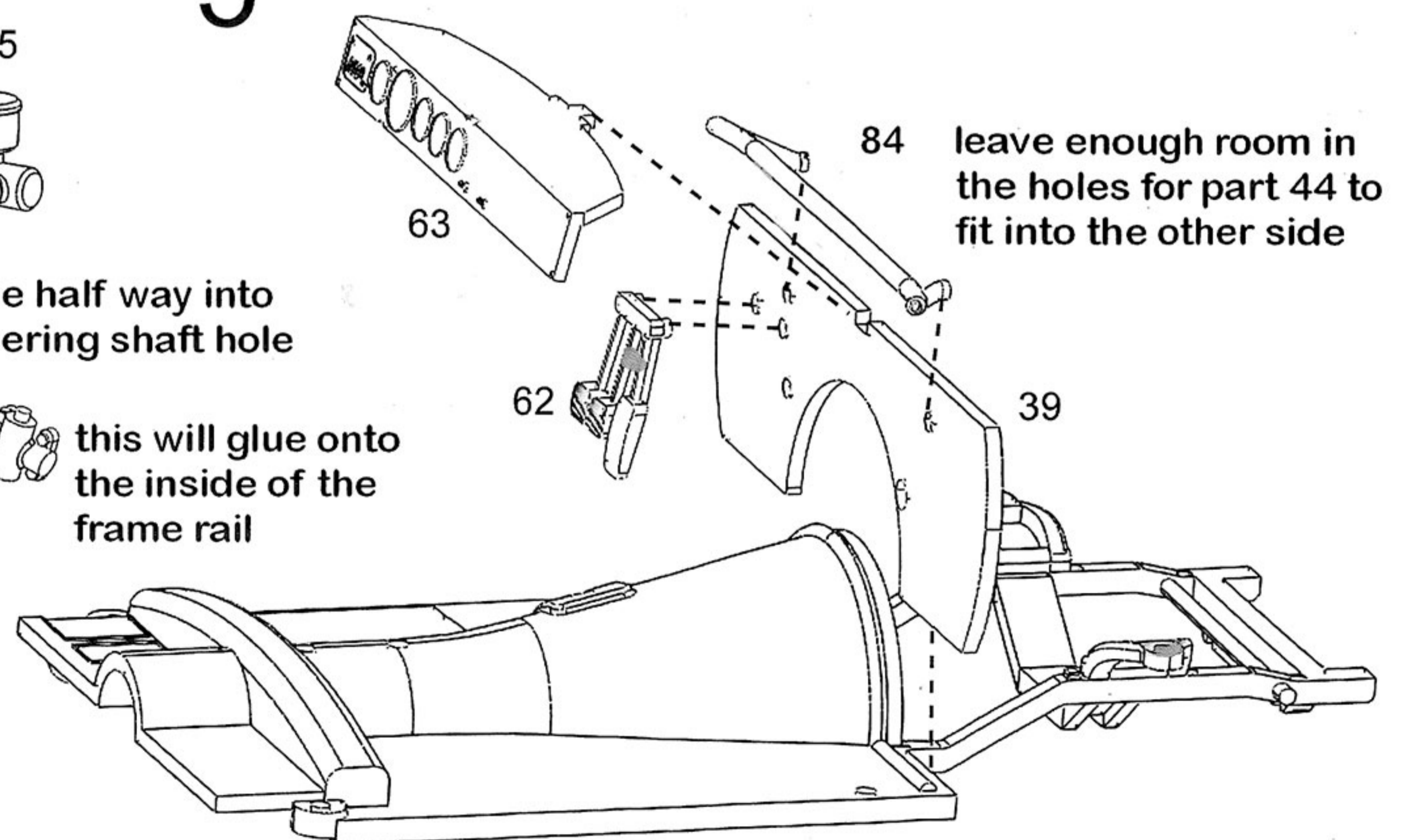

6

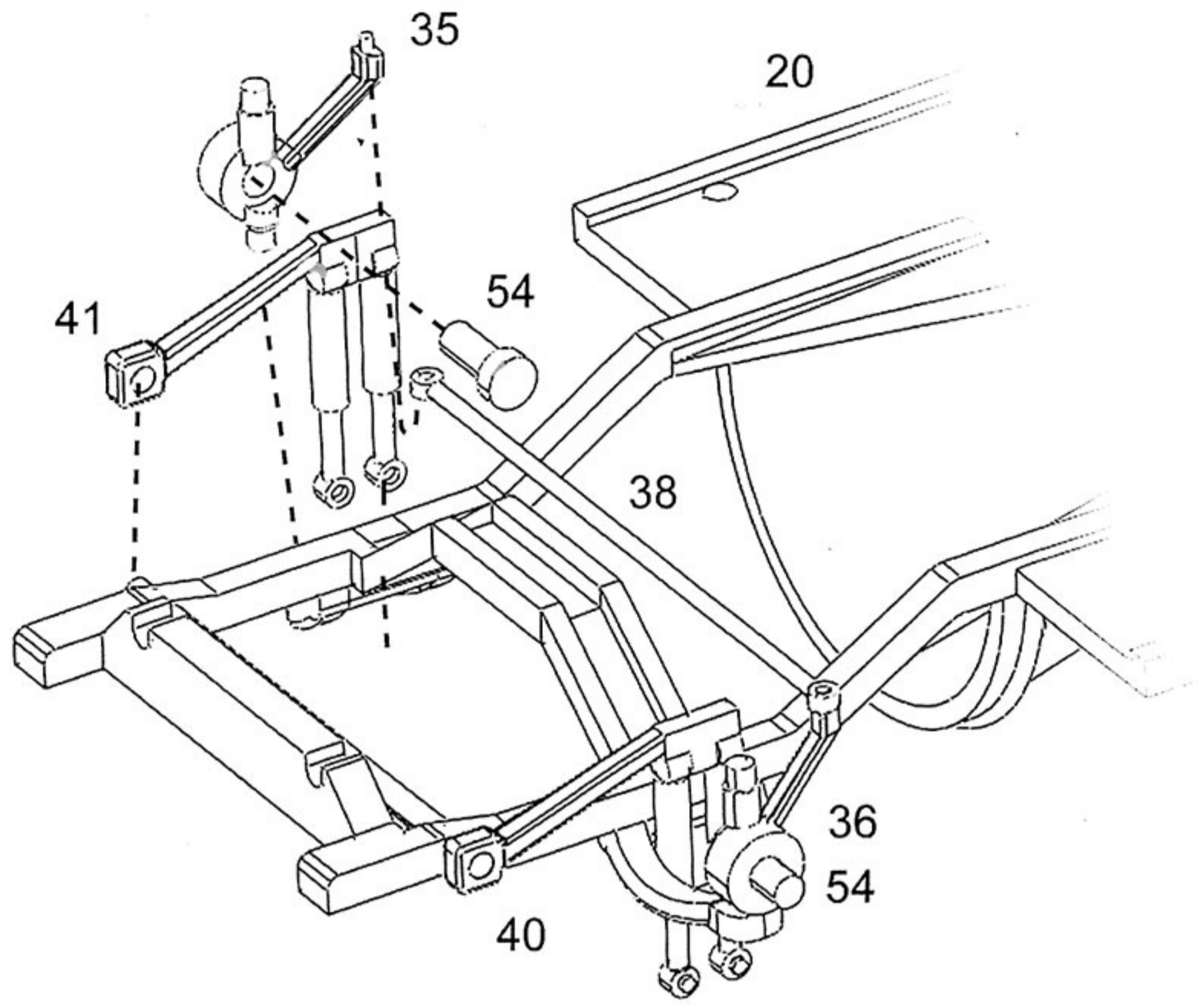

7

cut away from part 37 and discard the rest →

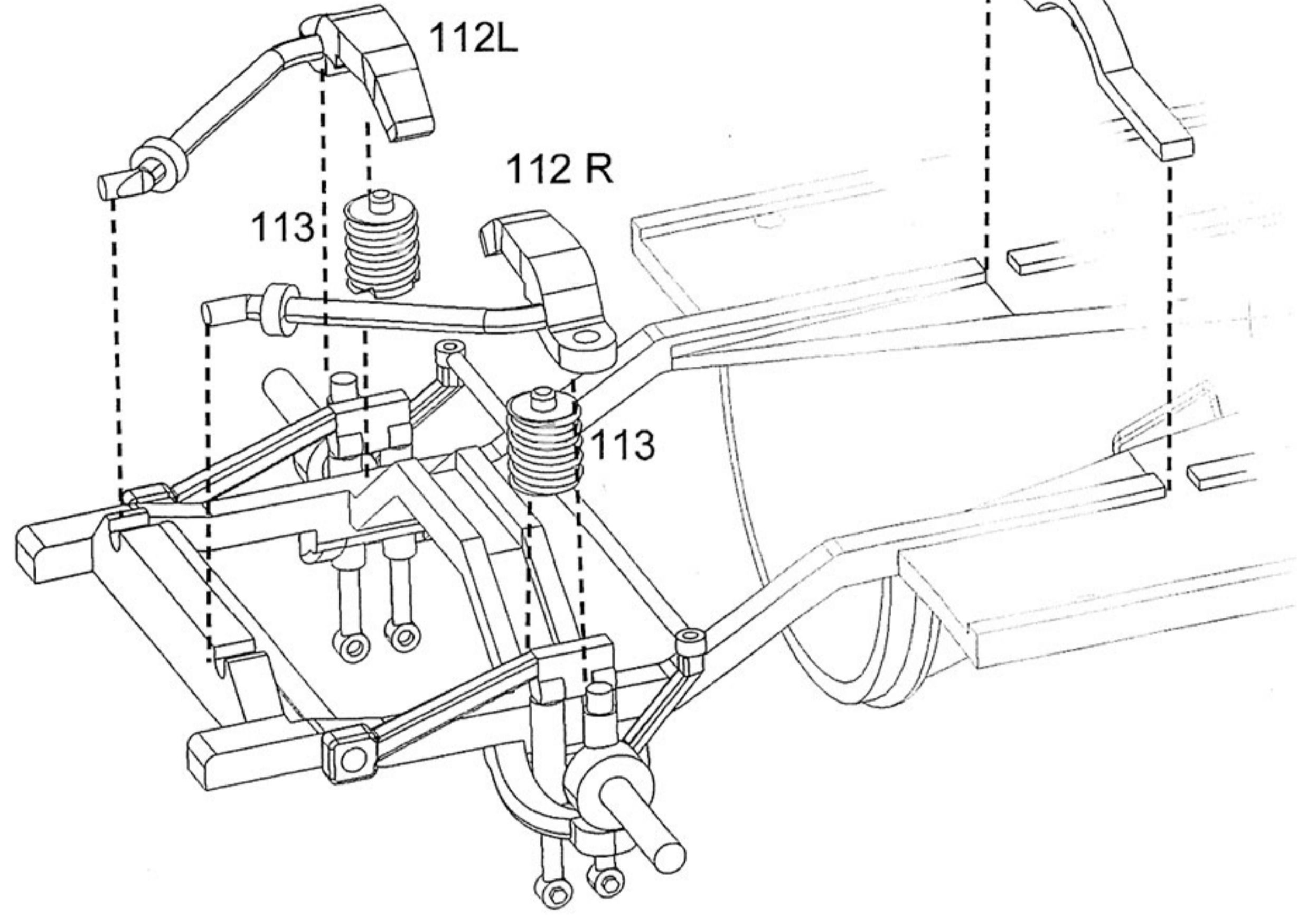

8

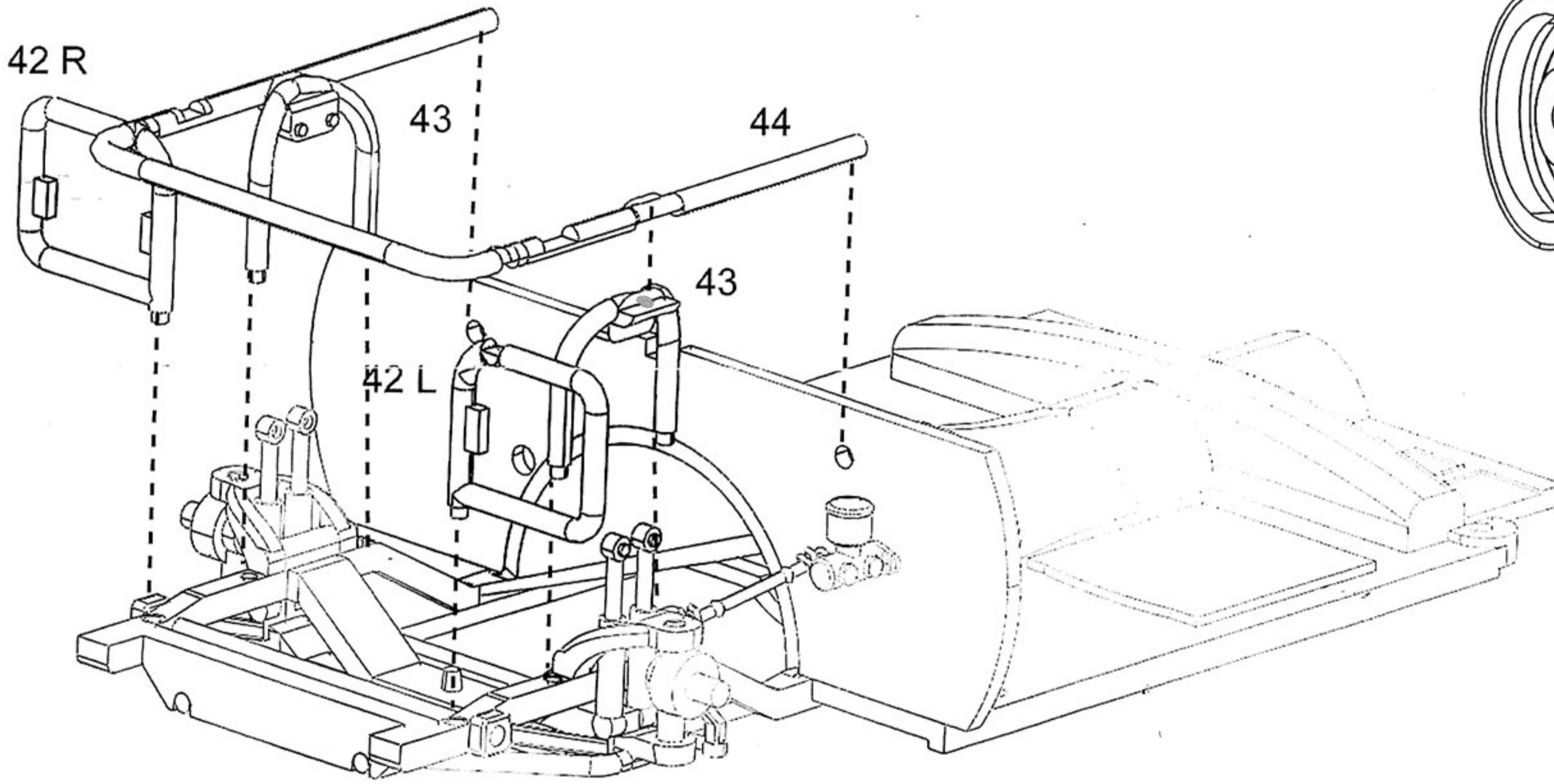

9

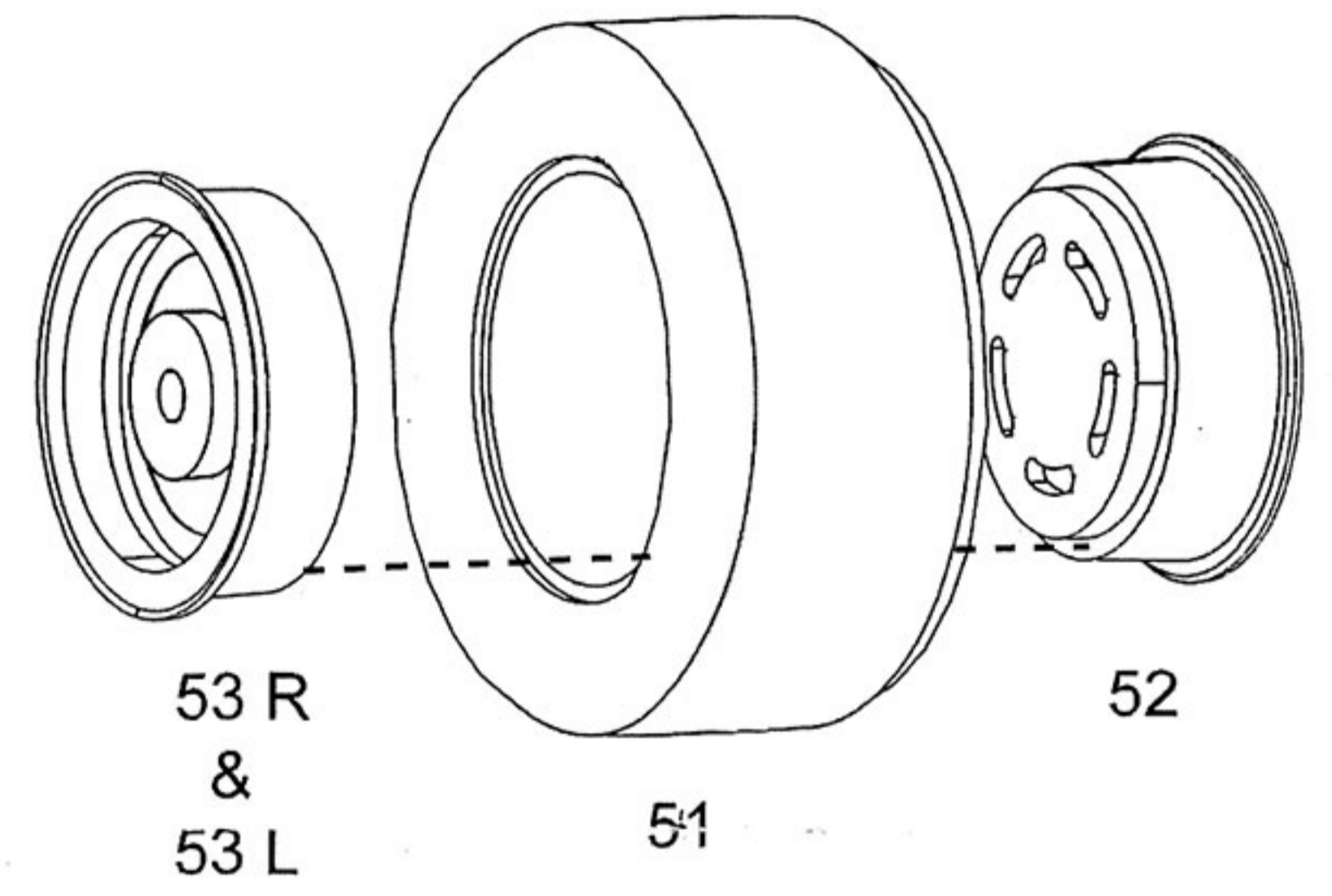

10

insert the engine assembly

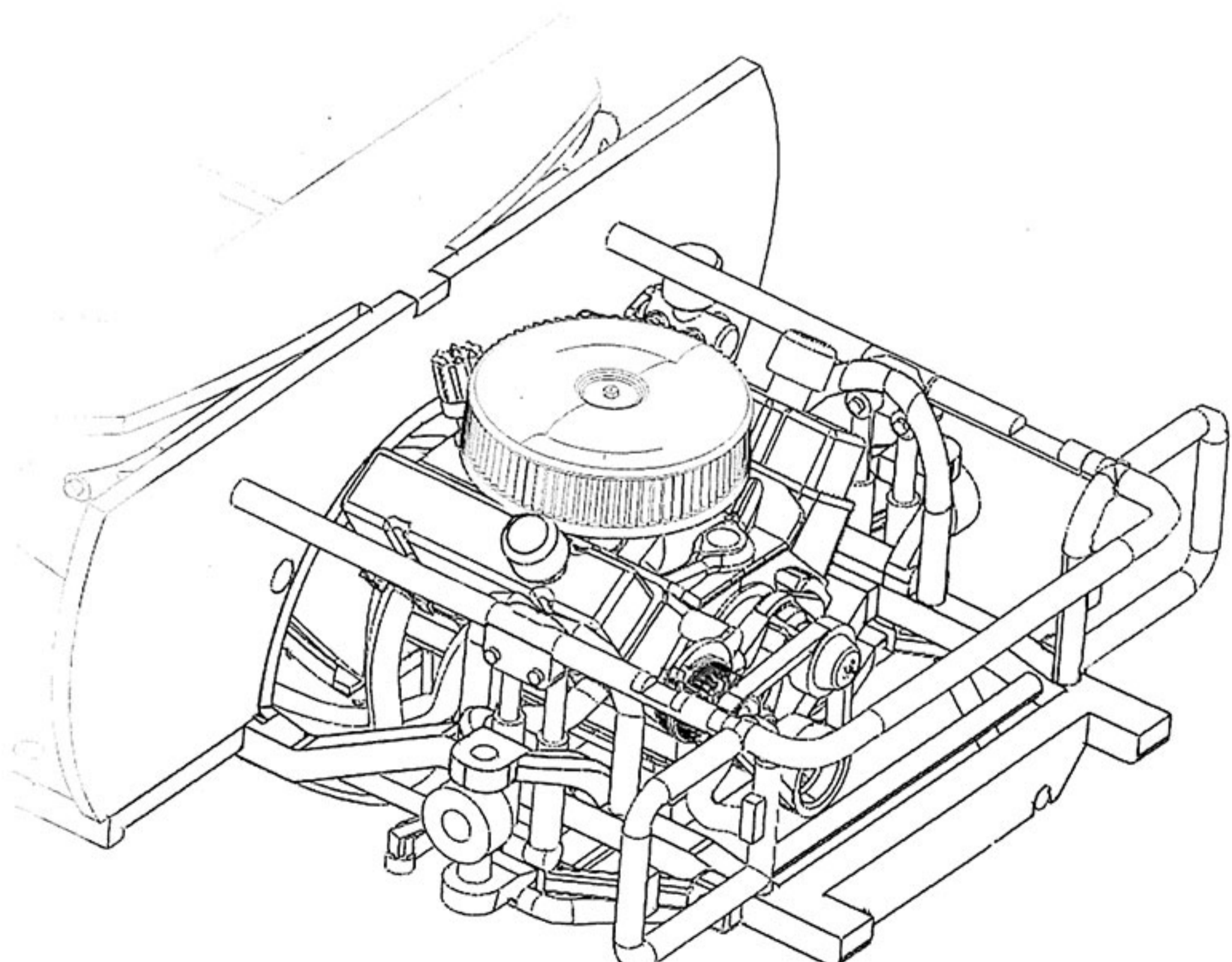

11

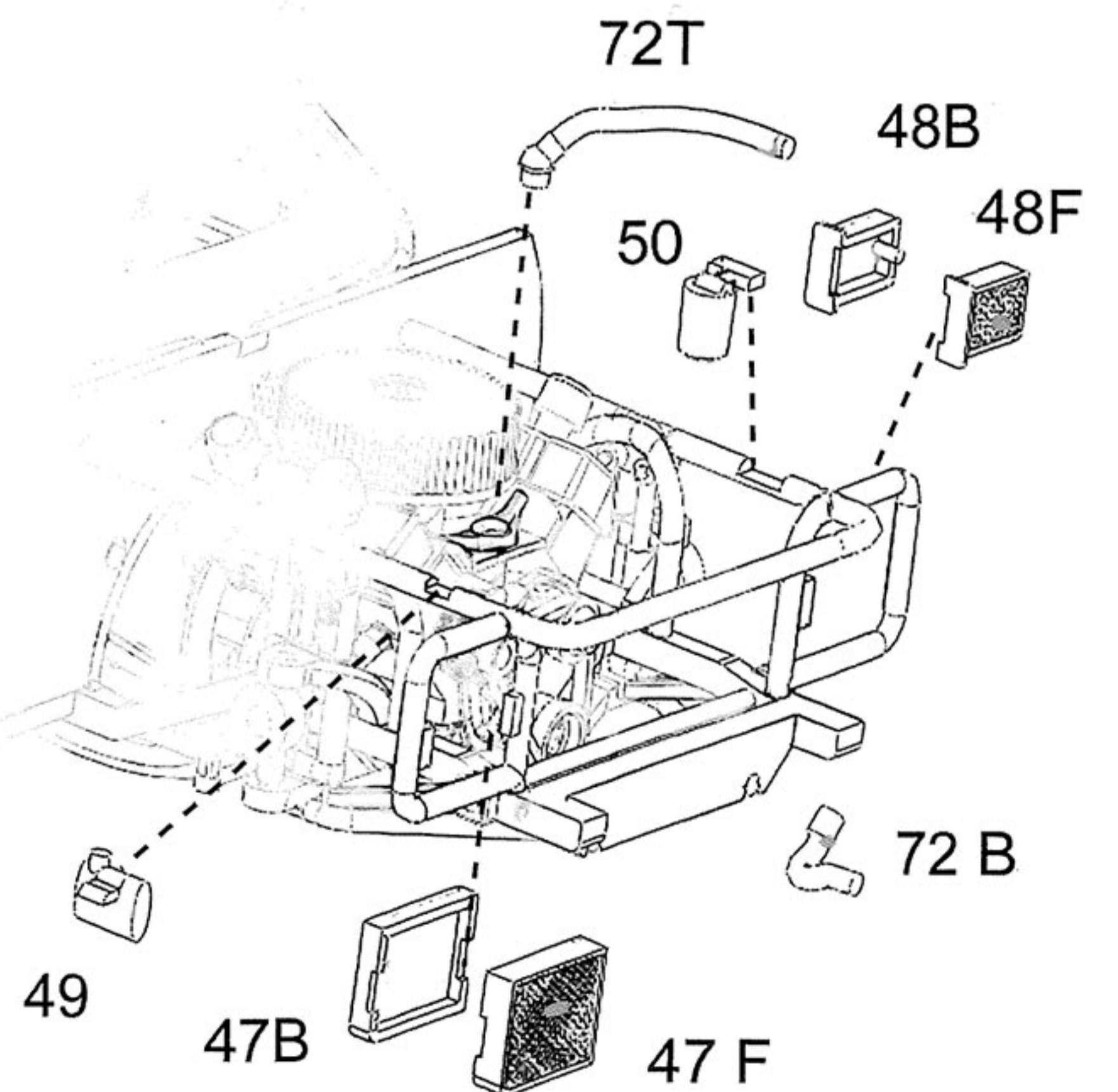

12

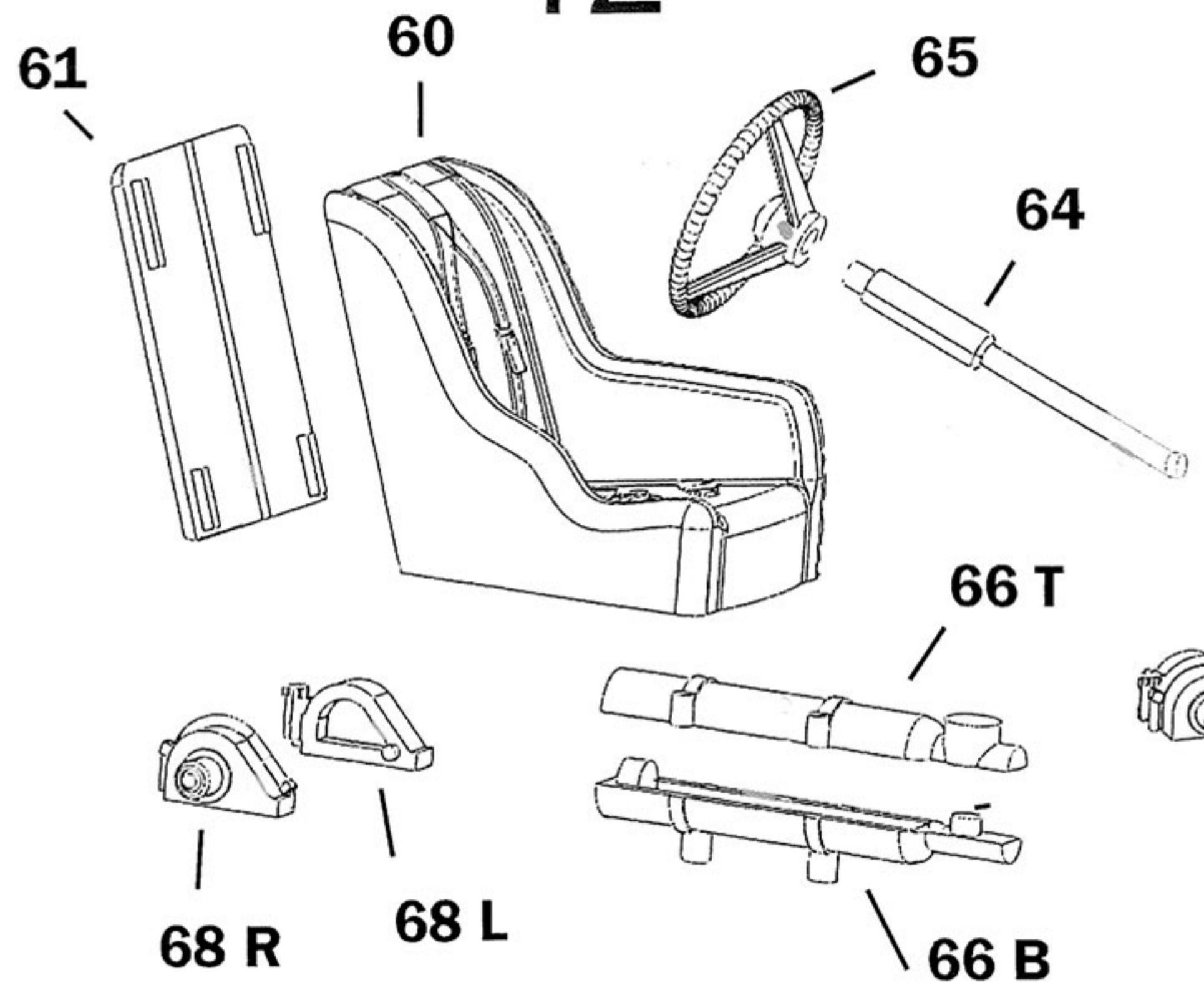

13

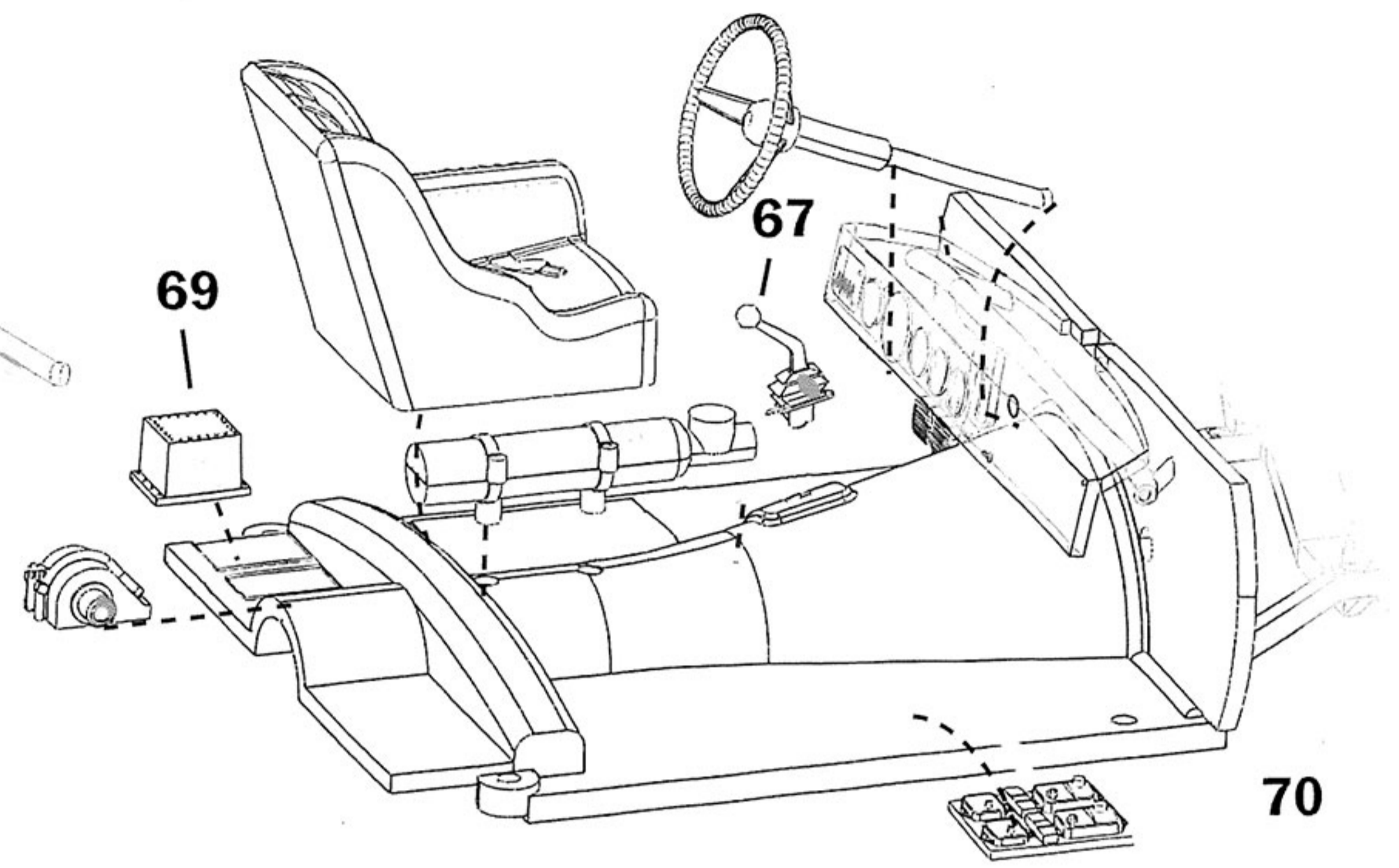

14

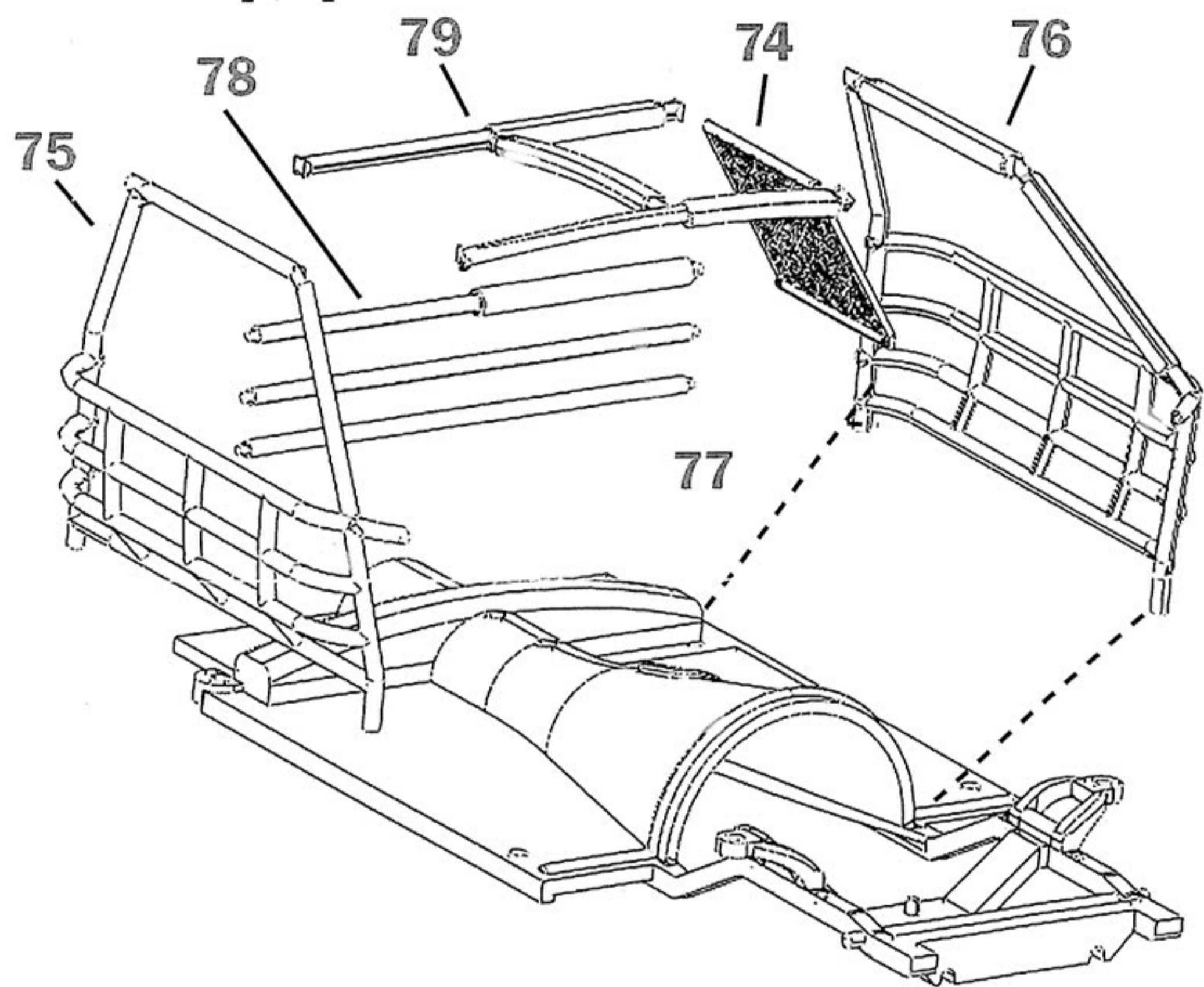

15

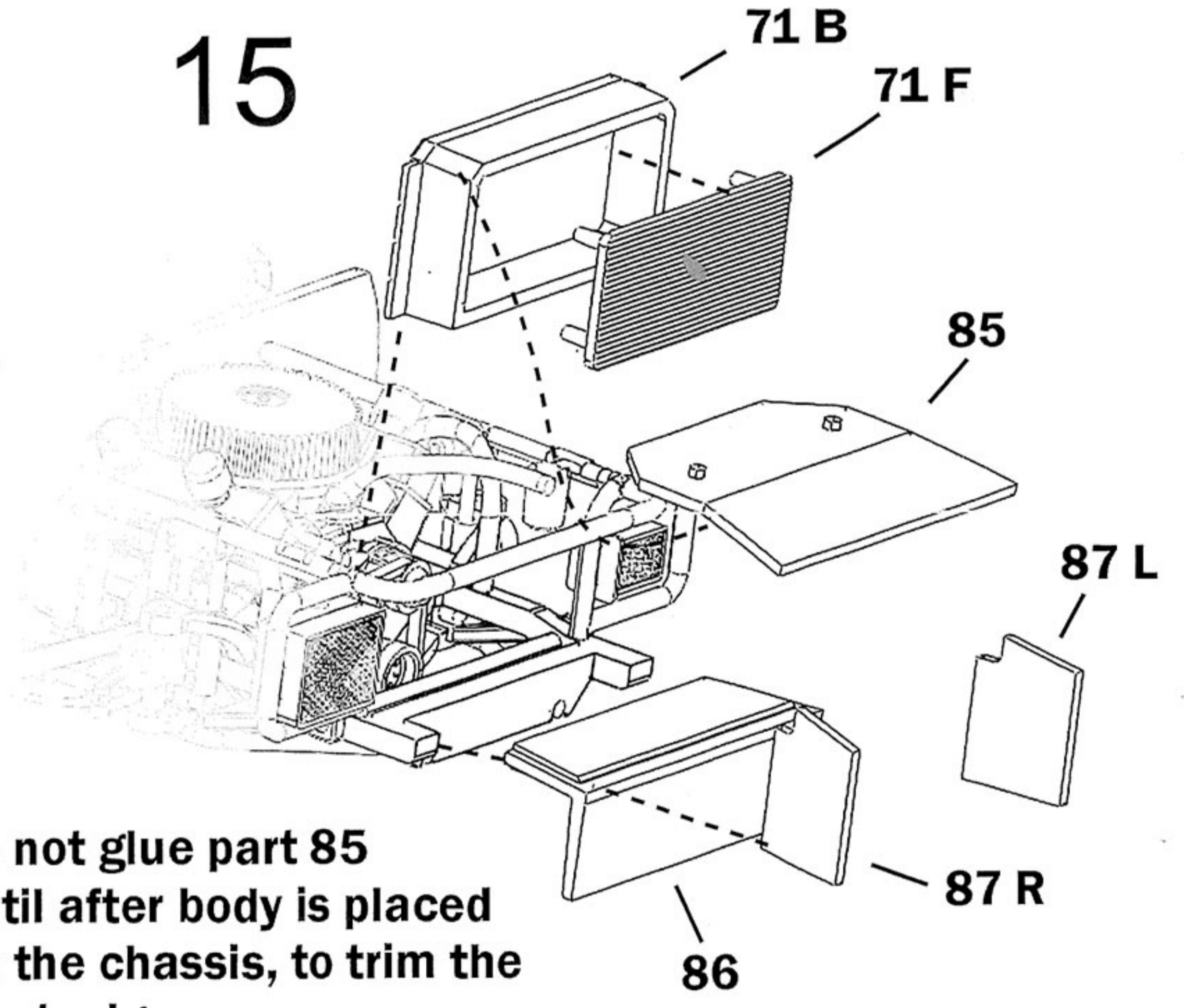

do not glue part 85 until after body is placed on the chassis, to trim the front edge

16

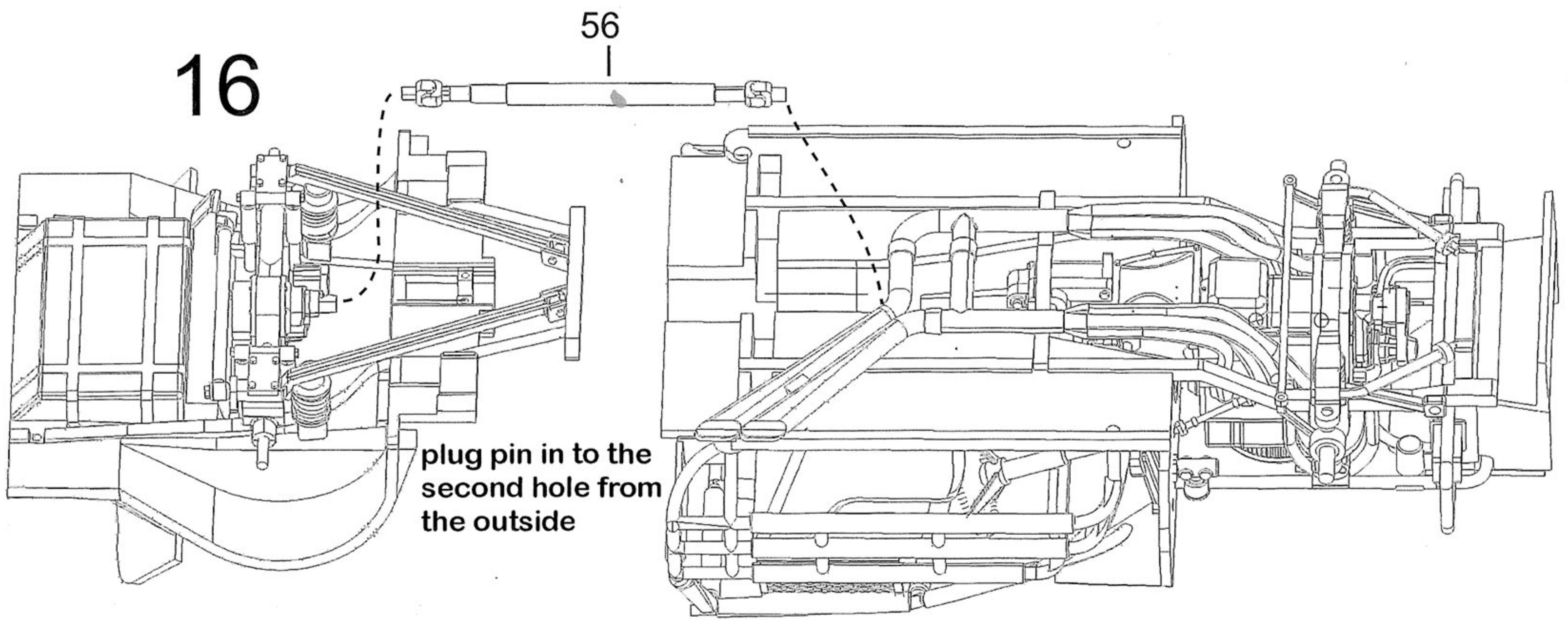

17

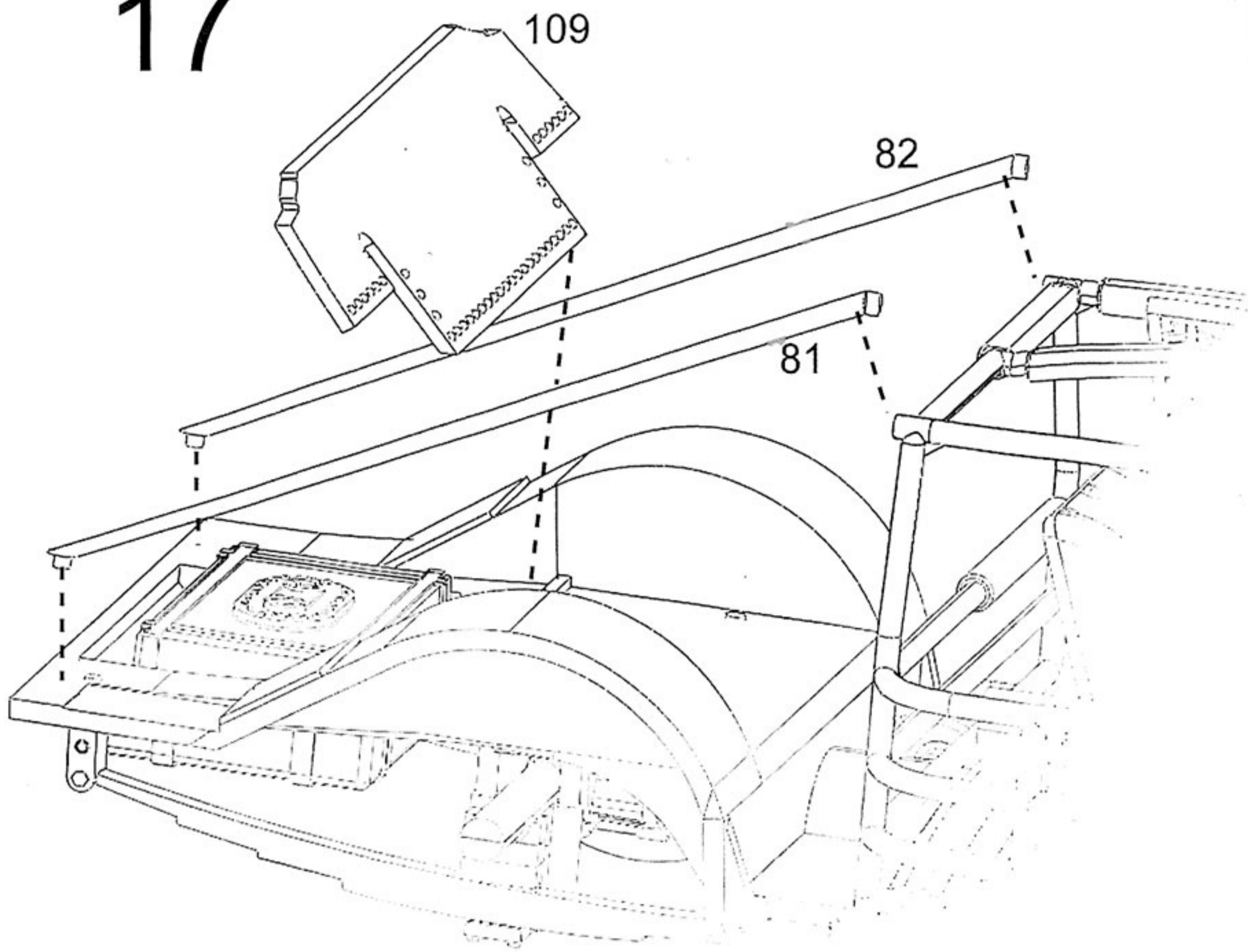

18

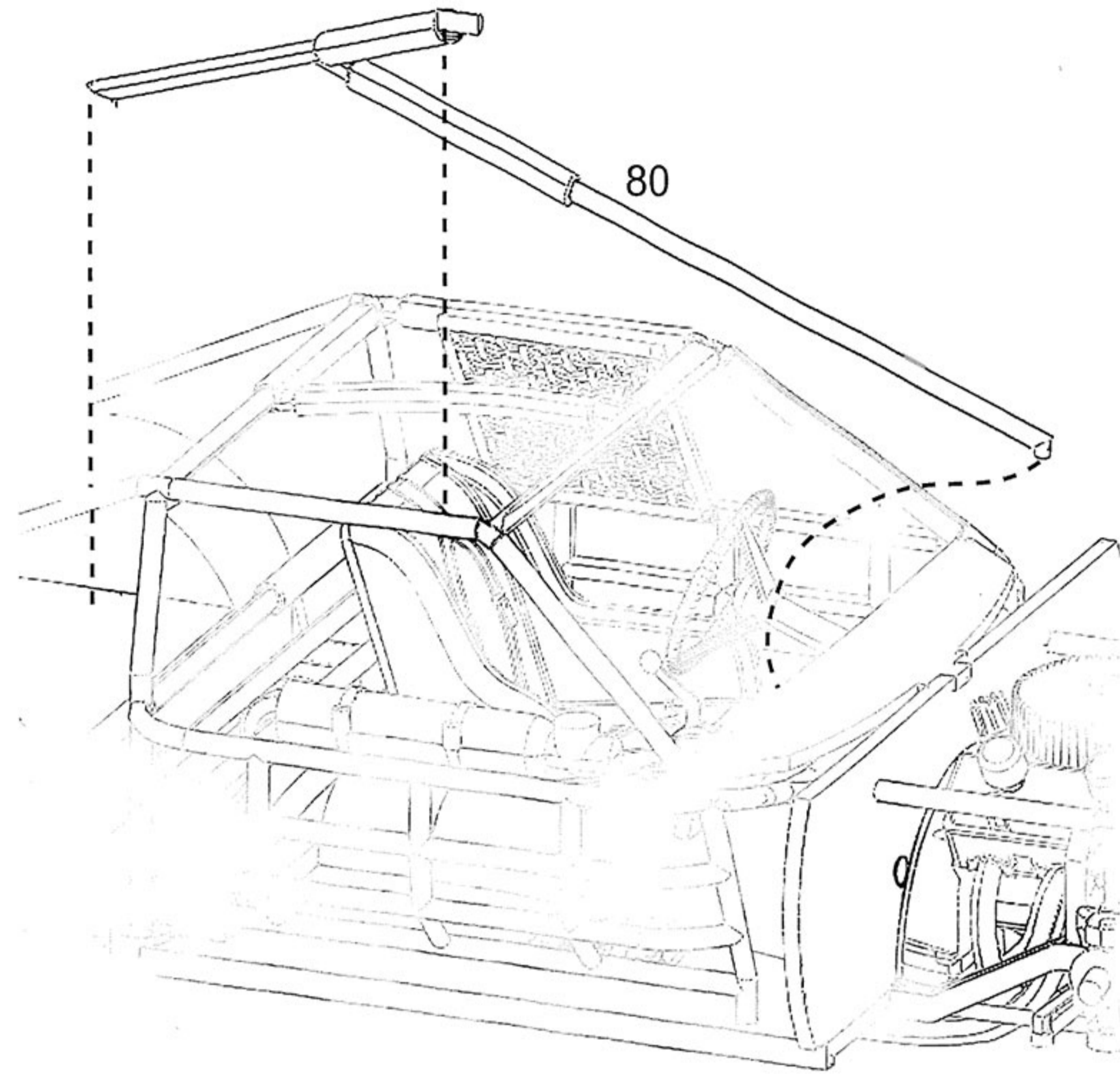

19

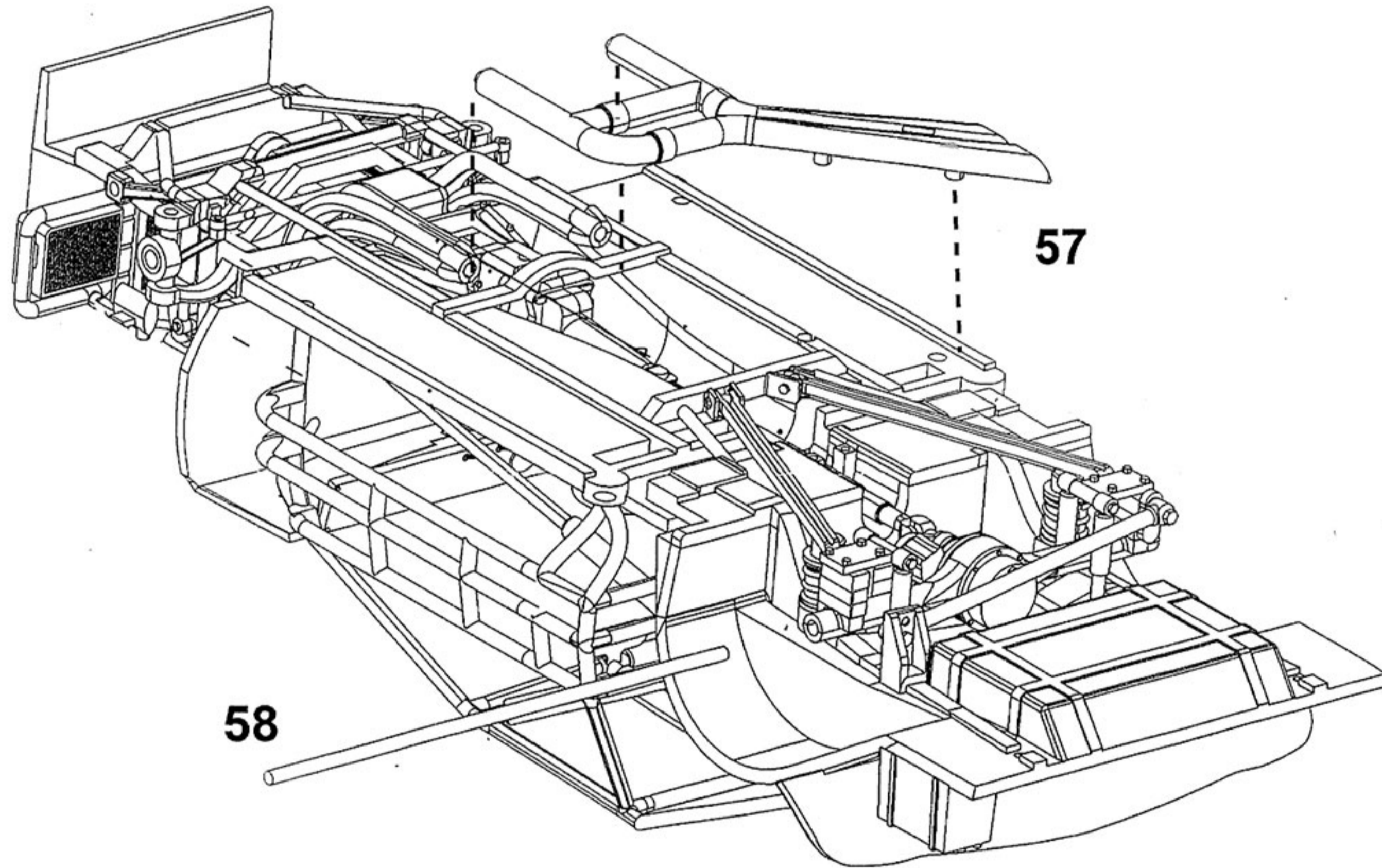

20

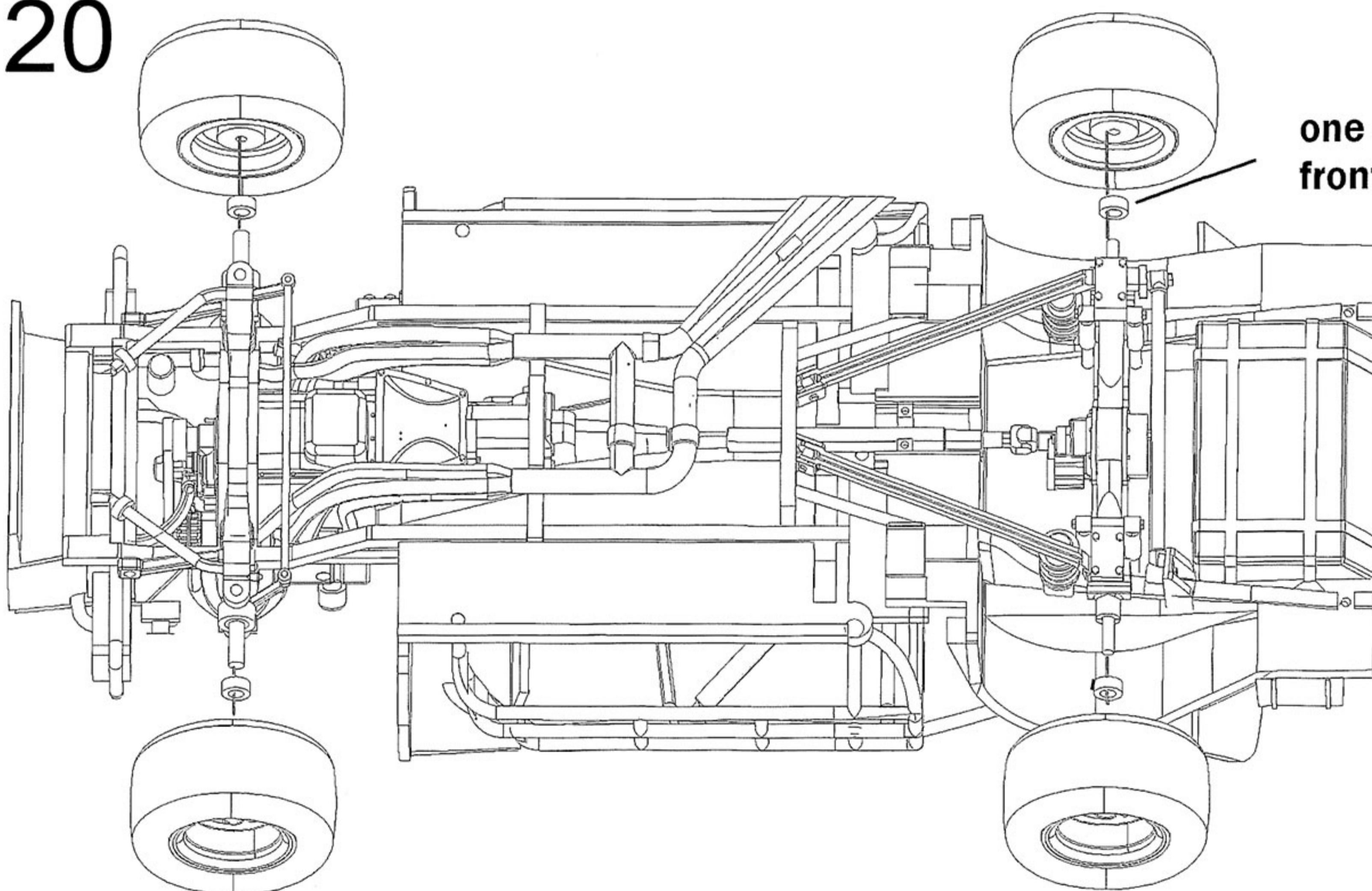

one wide spacer on each front and rear axle

21

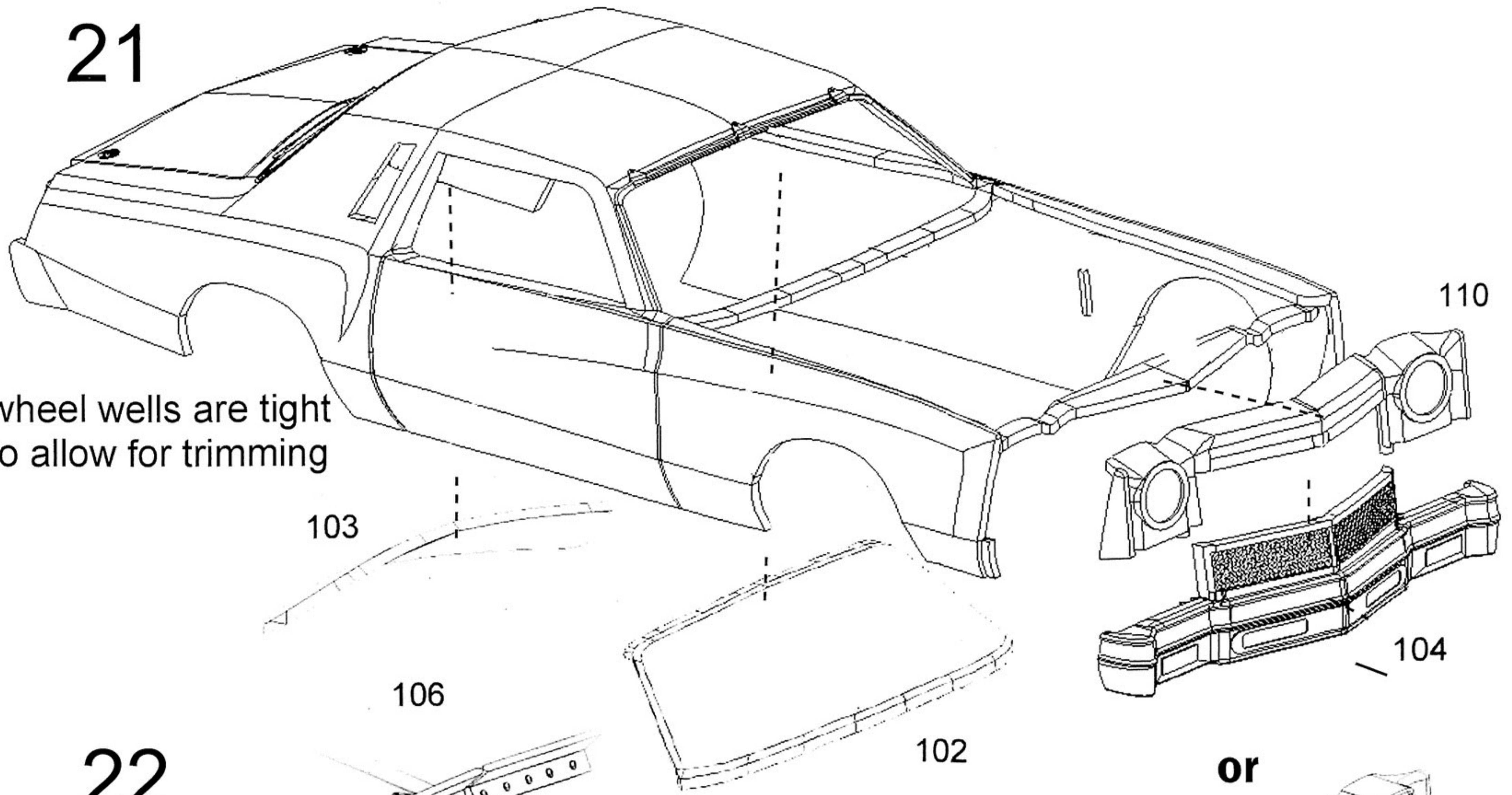

wheel wells are tight to allow for trimming

22

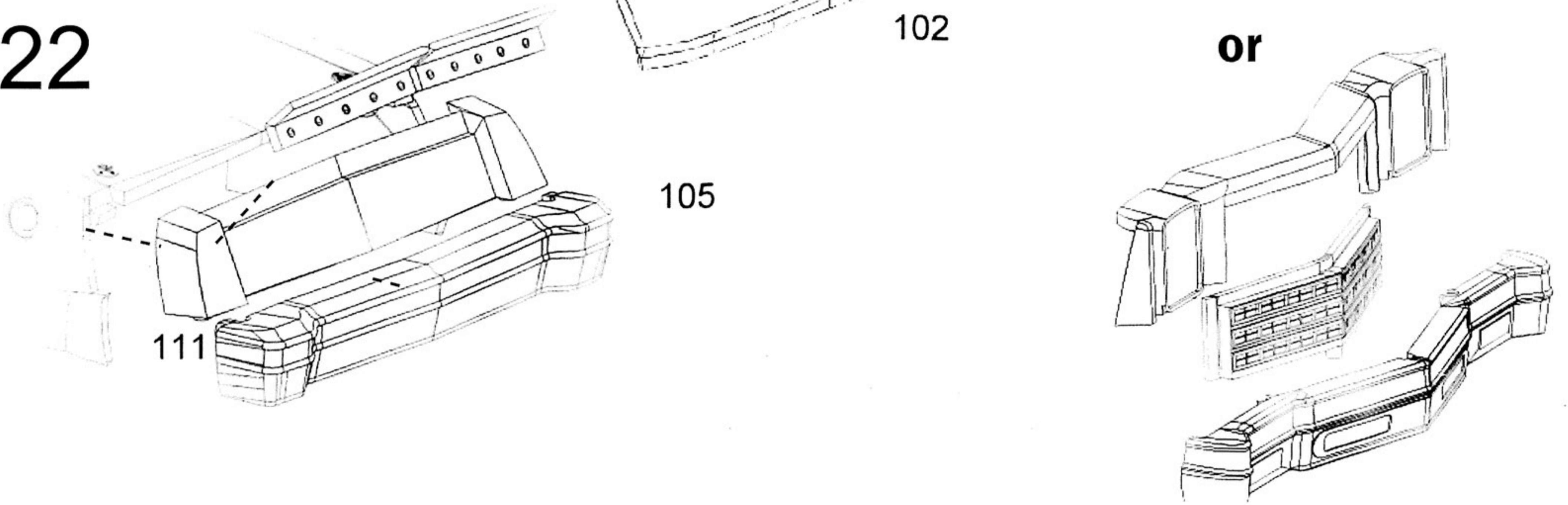

23

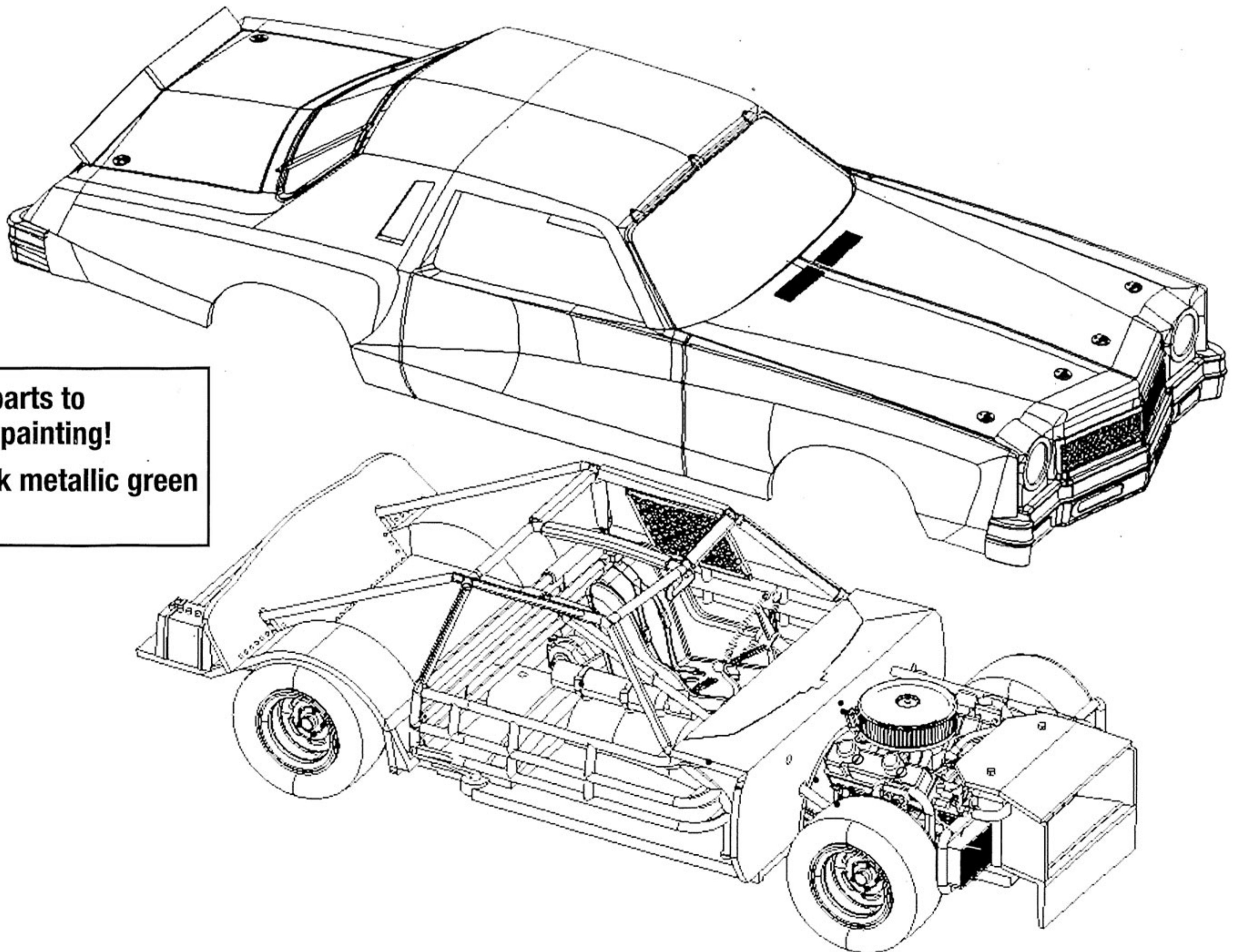

- Fit and trim all parts to the body before painting!
- Body paint: dark metallic green & gloss white